

WaterMaker^{FIVE}

WM5-50 5-Stage Reverse Osmosis System



Tested and Certified by WQA against
NSF/ANSI Standard 58 for the reduction of claims
specified on the Performance Data Sheet
and the CSA Standard B483.1 -
Drinking Water Treatment Systems.



42445 Avenida Alvarado
Temecula, CA 92590
800-451-9343, FAX 951-894-2801
www.nimbuswater.com

WaterMaker^{FIVE}

Introduction to the WaterMaker Five

Congratulations on your purchase of the WaterMaker Five reverse osmosis system. The WaterMaker Five features a four-stage prefilter, membrane and postfilter housed in a single cartridge. The fifth stage, an in-line carbon filter, is placed between tank and faucet.

When properly maintained, this system will provide you with years of trouble-free service. The next sections contain important information on the proper care and maintenance of your system, please take a few minutes to read through this information.

The cartridges in this system must be replaced on a regular basis to maintain efficiency and to ensure high water quality. These cartridges work together and must be replaced every 6-12 months. Any significant change in performance of the system should be investigated promptly to avoid secondary damage or deterioration to other parts of the system.

Normally, the reverse osmosis membrane is replaced during an annual filter change. However, if at any time you notice a reduction in water production or an unpleasant taste in the reverse osmosis water, it could be time to replace the membrane. Nimbus recommends replacing the membrane when TDS reduction falls below 85%.

In order to ensure the system is functioning properly, a water sample must be sent in to Nimbus every 6 months for a free diagnosis of your membrane performance. To send a water sample, use two clean containers and fill one with 1/2 cup of tap water and the other with 1/2 cup of RO water. Clearly label each sample. Send the samples to the address listed on the cover of this manual, attention "Water Sample Testing". Nimbus will test the samples and mail or call you with the results.

CAUTION: Improperly installed systems could result in water damage due to leaks or flooding. Proper installation of this system requires familiarity with standard sink plumbing and proper use of common hand and power tools. This system has been designed for installation by licensed professionals, such as a contractor or plumber.

Stage	Description	Replacement Interval	Part Number
1-4	4-Stage Cartridge 1) 20 micron sediment prefilter 2) Granular activated carbon prefilter 3) Reverse osmosis membrane 4) Granular activated carbon postfilter	12 months	104592
5	Granular activated carbon postfilter (inline between tank and faucet)	6-12 months	104803



The WaterMaker Five uses the latest in system design and membrane technology to reduce the amount of water down the drain by 50%.

The WaterMaker Five is smaller and uses significantly fewer resources in the manufacturing process than the typical 5-stage RO system.

Smaller packaging and a lighter shipping weight further reduce impact on the environment.

WaterMaker^{FIVE} Limited Warranty

This Limited Warranty extends to the original purchaser of the system only. This warranty covers all Manufacturer-supplied items only that prove to be defective in material, workmanship or factory preparation. This warranty covers parts only; all labor is excluded from this warranty, including, but not limited to, services related to the removal, replacement, installation, adjustment, maintenance and/or repair of the unit or its components items. excludes all non-Manufacturer labor required for any servicing of the unit, including, but not limited to, servicing related to installation, adjustment, maintenance and repair of the unit. This warranty applies only for the first full calendar year from date of purchase. The following items are excluded from this warranty: membranes, filters, O-rings, and all other parts or components that require regular replacement as a result of ordinary usage.

Disclaimers: This Limited Warranty applies only if the system is installed, used and maintained in compliance with all instructions and requirements enclosed with the system. This warranty will be void for failure to observe the following conditions:

1. The system is to be used with potable water from a municipal water system.
2. Feed water pressure to the unit is no less than 40 PSI and no greater than 80 PSI.
3. The system is to be used on water supplies with chlorine concentrations of 1.0 mg/L (ppm) or less.
4. Feed water temperature to the unit must be no less than 40°F and no more than 100°F.
5. Total dissolved solids in feed water must be less than 2,000 mg/L (ppm).
6. Feed water must have a pH between 4 and 8.
7. Turbidity must be less than 1.0 NTU.
8. SDI must be less than 5.
9. Feed water must be completely free of iron, manganese or hydrogen sulfide.

Do not use with water that is microbiologically unsafe or of unknown quality without adequate disinfection before or after the system.

The Manufacturer does not know the characteristics of your water supply. The quality of water supplies may vary seasonably or over a period of time. Your water usage may vary as well. Water characteristics can also change if the drinking water appliance is moved to a new location. The Manufacturer assumes no liability for the determination of the proper equipment necessary to meet your requirements, and we do not authorize others to assume such obligation on our behalf.

This Limited Warranty does not cover any Manufacturer-supplied items that are defective as a result of the use of improper parts, equipment or materials. This warranty does not cover alterations or modifications of the unit, or failure of a unit caused by such alterations and modifications

This Limited Warranty does not cover malfunctions of the unit due to tampering, misuse, alteration, lack of regular maintenance, misapplication, fouling due to hydrogen sulfide, manganese or iron, scaling from excessive hardness, turbidity greater than 1.0 NTU, Silt Density Index (SDI) greater than 5.0 SDI, or excessive membrane hydrolysis due to chlorine levels in excess of 1.0 mg/L (ppm). In addition, damage to the unit due to fire, accident, negligence, act of God, or events beyond the control of the Manufacturer are not covered by this warranty.

Incidental and Consequential Damages Limitation: The Manufacturer will not be responsible for any incidental or consequential damages as a result of the failure of this unit to comply with express or implied warranties or any defect in the unit, including but not limited to, lost time, inconvenience, damage to personal property, loss of revenue, commercial losses, postage, travel, telephone expenditures, or other losses of this nature. Some states do not allow the exclusion or limitation of incidental or consequential damages, so this exclusion may not apply to you.

Owner's Warranty Responsibilities: As a condition of this Limited Warranty, the owner must ensure periodic maintenance of the system is performed as described in the literature enclosed with the system. Neglect, improper maintenance, abuse, modification or alteration of the unit will invalidate this Warranty. Should your unit develop a defect or otherwise fail to perform in accordance with this warranty, you should contact the retailer from whom the product was originally purchased.

Implied Warranties: The implied at-law warranties of merchantability and fitness for a particular purpose shall terminate on the date one year after the date of purchase. Note: some states do not allow limitations on how long an implied warranty lasts, so the above limitations may not apply to you.

Other Rights: This Warranty gives you specific legal rights and you may also have other rights which vary from state to state.

WaterMaker^{FIVE} Performance Data Sheet

System Performance

This system has been tested according to NSF/ANSI 58 for reduction of the substances listed below. The concentration of the indicated substances in water leaving the system was reduced to a concentration less than or equal to the permissible limit for water leaving the system, as specified in NSF/ANSI 58. This system has also been tested and certified against CSA Standard B483.1 - Drinking Water Treatment Systems. Do not use with water that is microbiologically unsafe or of unknown quality without adequate disinfection before or after the system. Systems certified for cyst reduction may be used on disinfected water that may contain filterable cysts.

This system has been tested for the treatment of water containing pentavalent arsenic (also known as AS(V), As⁺⁵, or arsenate) at concentrations of \leq 300 ppb. This system reduces pentavalent arsenic, but may not reduce other forms of arsenic. This system is to be used on water supplies containing a detectable free chlorine residual at the system outlet or on water supplies that have been demonstrated to contain only pentavalent arsenic. Treatment with chloramine (combined chlorine) is not sufficient to ensure complete conversion of trivalent arsenic to pentavalent arsenic. Please see the Arsenic Facts section of the Performance Data Sheet for further information.

Testing was performed under standard laboratory conditions, actual performance may vary. Incoming water must be free of potential membrane foulants such as Iron, Hydrogen Sulfide and Manganese. Efficiency rating means the percentage of the influent water to the system that is available to the user as reverse osmosis treated water under operating conditions that approximate typical daily usage. Recovery rating means the percentage of the influent water to the membrane portion of the system that is available to the user as reverse osmosis treated water when the system is operated without a storage tank or when the storage tank is bypassed.



Model Number: WaterMaker Five, WM5-50
 Avg. Recovery: 30.7%
 Temperature: 4°C - 38°C (40°F - 100°F)

Avg Daily Production Rate: 67.76 L/d (17.9 gpd)
 Avg Efficiency: 17.8%
 Pressure: 2.81 - 5.62 kg/cm² (40-80 psi)

	Influent Challenge Concentration	Maximum Allowable Concentration	Actual Minimum % Reduction	Average Percent Reduction
Arsenic (pentavalent)	50 ppb	10 ppb	98.1	99.0
Barium	10.0 mg/L \pm 10%	2.0 mg/L	95.0	98.8
Cadmium	0.03 mg/L \pm 10%	0.005 mg/L	94.0	98.3
Chromium 6 (Hexavalent)	0.3 mg/L \pm 10%	0.1 mg/L	95.5	98.3
Chromium 3 (Trivalent)	0.3 mg/L \pm 10%	0.1 mg/L	98.4	99.0
Copper	3.0 mg/L \pm 10%	1.3 mg/L	95.0	98.4
Cysts	Min 50,000/mL	110 counts/mL	>99.99	>99.99
Fluoride	8.0 mL \pm 10%	1.5 mL	87.0	93.8
Lead	0.15 mL \pm 25%	0.010 mL	90.4	96.8
Radium 226/228	25 pCi/L \pm 10%	5 pCi/L	95.0	98.8
Selenium	0.10 mg/L \pm 10%	0.05 mg/L	94.4	97.9
Turbidity	11 \pm 1 NTU	0.5 NTU	96.4	98.7
TDS (Total Dissolved Solids)	740 mL	187 mL	86.6	93.1

System Maintenance

This reverse osmosis system contains a replaceable component critical to the efficiency of the system. Replacement of the reverse osmosis component should be with one of identical specifications, as defined by the manufacturer, to ensure the same efficiency and contaminant reduction performance. System manual at www.nimbuswater.com/products/residential/watermakerfive.html. Feed water conditions may affect replacement intervals.

Part Number	Description	Replacement Interval
104592	TF50, 4 stage cartridge	12 months
104803	5th stage inline post filter	6-12 months

WaterMaker^{FIVE} Arsenic Fact Sheet

Arsenic (AS) is a naturally occurring contaminant found in many ground waters. Arsenic in water has no color, taste or odor. It must be measured by a lab test. Public water utilities must have their water tested for arsenic. You can get the results from your water utility. If you have your own well, you can have the water tested. The local health department or the state environmental health agency can provide a list of certified labs. The cost is typically \$15 to \$30. Information about arsenic in water can be found on the Internet at the US Environmental Protection Agency website: www.epa.gov/safewater/arsenic.html.

There are two forms of arsenic: pentavalent arsenic (also called AS(V), As⁺⁵, and arsenate) and trivalent arsenic (also called AS(III), As⁺³, and arsenite). In well water, arsenic may be pentavalent, trivalent, or a combination of both. Special sampling procedures are needed for a lab to determine what type and how much of each type of arsenic is in the water. Check with the labs in your area to see if they can provide this type of service.

Reverse osmosis (RO) water treatment systems are very effective at removing pentavalent arsenic. RO systems do not remove trivalent arsenic from water very well. A free chlorine residual will rapidly convert trivalent arsenic to pentavalent arsenic. Other water treatment chemicals such as ozone and potassium permanganate will also change trivalent arsenic to pentavalent arsenic. A combined chlorine residual (also called chloramine) may not convert all the trivalent arsenic. If you get your water from a public water utility, contact the utility to find out if free chlorine or combined chlorine is used in the water system.

The WM5-50 system is designed to remove pentavalent arsenic. It will not convert trivalent arsenic to pentavalent arsenic. The system was tested in a lab. Under those conditions, the system reduced 300 ppb pentavalent arsenic to 10 ppb (the USEPA standard for drinking water) or less. The performance of the system may be different at your installation. Have the water tested for arsenic to check if the system is working properly.

The RO component of the WM5-50 system must be replaced yearly to ensure the system will continue to remove pentavalent arsenic. The component identification and location where you can purchase the component are listed in the installation/operation manual.

WaterMaker^{FIVE} System Specifications

Dimensions and Weight

System - 9.75" W x 13.5" D x 15.5" H (24.8 x 34.3 x 39.4 cm), 11 lbs. (5 kg.)
 Shipping Box - 14.5"L x 11.25"W x 20"H (36.8 x 28.6 x 50.8 cm), 13.7 lbs. (6.2 kg.)

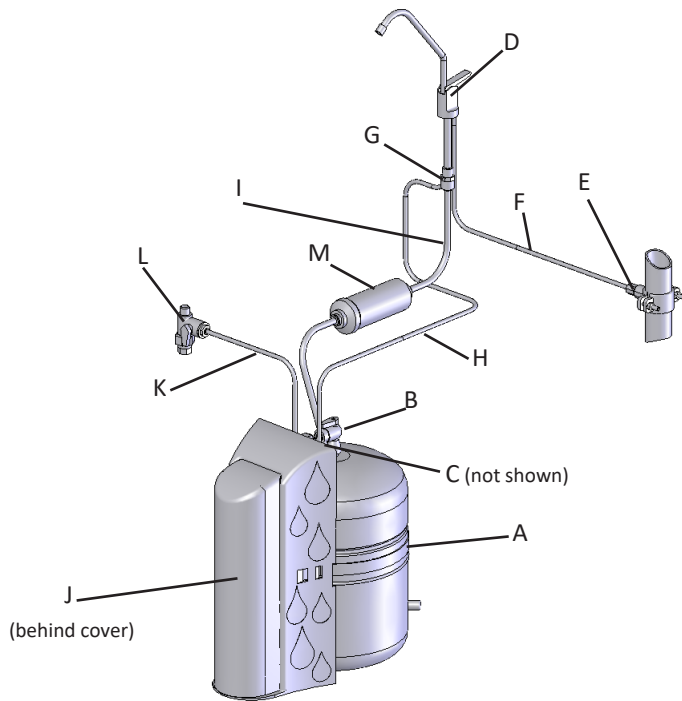

- A. Product water storage tank
- B. Tank valve
- C. Tank tubing (3/8" white)
- D. Air-gap faucet
- E. Drain connection assembly
- F. Drain tubing (3/8" white)
- G. Quick connect fitting
- H. Drain tubing (1/4" black)
- I. Faucet tubing (3/8" blue)
- J. Four-stage desalinator
- K. Feed water tubing (1/4" green)
- L. Feed valve assembly (with adapter and shut-off valve).
- M. Carbon post-filter

This system has been designed for installation by a licensed professional such as a contractor or plumber. Proper completion of this installation will require basic familiarity with standard sink plumbing and proper use of common hand and power tools. Improperly installed systems could result in water damage due to leaks or flooding.

Performance Specifications

Membrane Production System	50 GPD
Production	14.61GPD
TDS Rejection	96.5%
Recovery ¹	26.76%
<i>System tested at 50 psig, 750ppm TDS at 77°F.</i>	
¹ The percentage of the feed water available as reverse osmosis treated water under normal operating conditions.	

Feed Water Requirements

Pressure	40-80 psi (275 kPa - 552 kPa)
Temp	40°F - 100°F (4°C - 38°C)
TDS	<2000 mg/L
Chlorine	<1.0 mg/L
Turbidity	<1 NTU
SDI	<5
pH	4-8
<i>Feed water must be potable, municipal water. Must be free of potential membrane foulants such as Iron, Hydrogen Sulfide and Manganese.</i>	

Do not use with water that is microbiologically unsafe or of unknown quality without adequate disinfection before or after the system.

WaterMaker^{FIVE} Push Handle Airgap Faucet

Note: This faucet requires a 1¼" opening in the sink or countertop.

1. Locate the faucet parts bag and arrange the parts on the countertop in the sequence shown.
2. The last part in the sequence, the quick connect adapter (6), will be found in the smaller parts bag.
3. Locate the piece of white tubing. Pull the white, black and blue tubing up through the faucet hole in the sink.
4. Insert polished faucet base and rubber seal onto base of faucet.
5. Push the 1/4" black drain tubing attached to the system onto the smaller 1/4" barb located on the faucet base.
6. Push the 3/8" white tubing onto the larger 3/8" fitting located on the faucet base.
7. Slide white plastic spacer open-end-up onto the threaded faucet stem (2). Note: This spacer may be omitted if faucet is installed in a granite countertop (or countertop with similar thickness).
8. Loosely thread the 3/8" washer (3), the serrated washer (4) and mounting lock nut (5) onto the threaded stem. Leave enough space for the slotted washer which will be used in step 11.
9. Thread faucet quick-connect adapter (6) on to threads of faucet stem. NOTE: This connection should be hand-tightened only. Push one end of 3/8" blue tubing into 3/8" connection.
10. Push the tubing down into the faucet hole and position the faucet to the approximate orientation.
11. From underneath the sink, slip the slotted washer (1) between the white plastic spacer and the sink. Check the orientation of the faucet on the sink. Securely tighten the mounting nut with a wrench.
12. If necessary, firmly insert spout assembly into the top hole of faucet body (approximately 1/4"). You may swivel the faucet left or right.

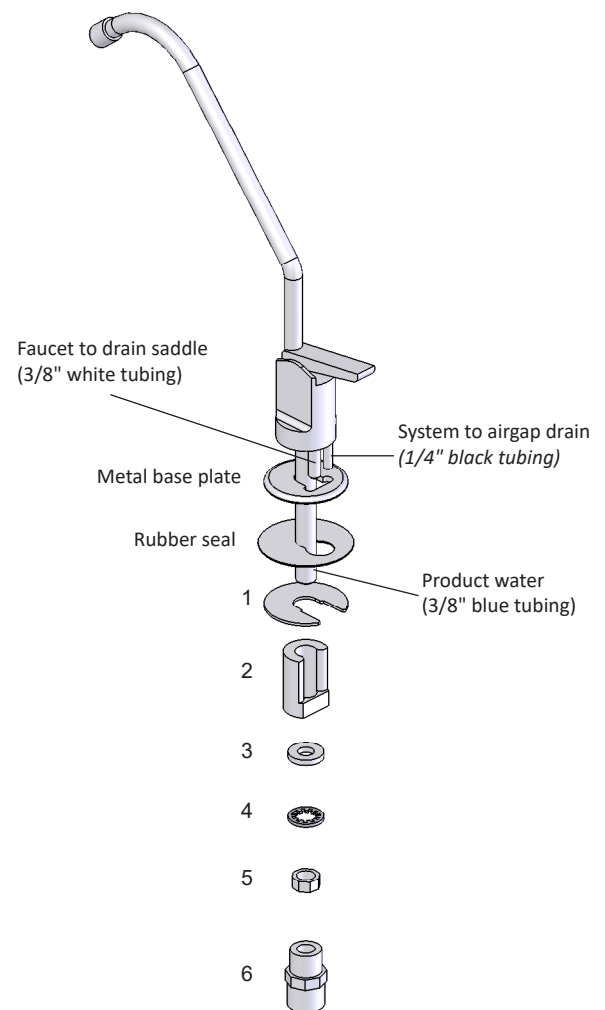

WaterMaker^{FIVE} Feed and Drain Connection

Feed Connection

1. Locate and turn off the angle stop valve on the cold water line feeding the sink. This valve will usually be located under the sink on the pipe coming out of the wall.
2. When the angle stop valve is closed, relieve pressure in the line by momentarily opening the cold water tap on the sink.
3. Disconnect the cold water faucet feed line at the angle stop valve.
4. Install the feed valve assembly into the angle stop. (Fig. 1)
5. Firmly press the green 1/4" tubing into the 1/4" connector on the feed valve assembly.
6. Connect the cold water faucet feed line into the feed valve assembly.
7. Make sure the small shut-off valve on the feed valve assembly is closed. Turn on the feed water connection valve. Check for leaks.
7. Attach the small feed valve warning tag from the parts bag to the feed valve.
8. Attach the Shutoff Warning label to the system so that it is directly visible. Fill out the Date of Installation label and attach to the side of the system.

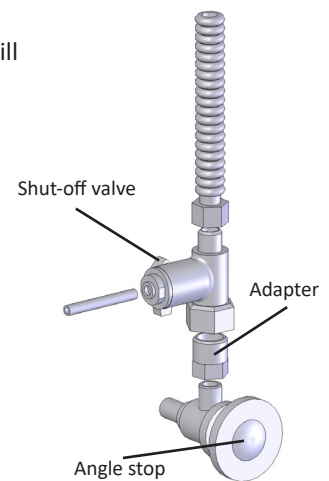

Fig. 1

Note: The feed valve adapter may be configured to fit either a 3/8" or 1/2" angle stop connection by changing the location of the adapter.

Drain Connection

1. You will need an electric drill with a 3/8" bit and a screwdriver for this portion of the installation.
2. Obtain the drain saddle assembly, two 1 1/2" bolts, two 3/8" hex nuts, and the small adhesive foam pad from the small parts bag (Fig. 2).
3. Place the adhesive foam pad on the inside of the drain saddle front, aligning the holes.
4. Position the drain saddle on the drain pipe under the sink between the "P" trap and the sink connection. Orient the drain saddle so that the opening is on the side of the drain pipe.
5. Using the bolts and hex nuts, hand tighten the saddle bracket evenly until the saddle grips the pipe snugly. Use a Phillips screwdriver to fully tighten the bolts. Do not overtighten.
6. If necessary, remove the drain saddle connector nut from the opening of the drain saddle. Using the connector opening in the side of the drain saddle as a guide, drill a 3/8" hole through the wall of the drain pipe.
7. Extend the drain tubing from the RO dispensing faucet to the drain saddle and measure for length. The tubing must be routed so that water can run downhill for the entire length of the tubing from the faucet. Avoid low spots or loops. Cut the tubing shorter, if necessary.
8. Insert the drain tube from the R.O. dispensing faucet through the drain saddle connector nut. Tighten the connector nut onto the drain saddle.

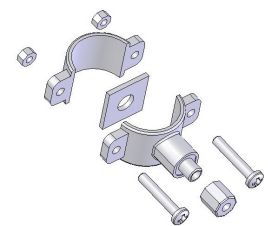

Fig. 2

Note: The drain saddle assembly must be installed before the 'P' trap. Do not install the drain saddle assembly between the 'P' trap and the wall.

System Activation and Inspection

1. Check all tubing connections to ensure they are firmly seated. CHECK TO SEE THAT THE CARTRIDGE RETAINER CLIP IS PROPERLY ENGAGED AND LOCKED. Failure to keep the retaining clip in place will result in accidental leaks and flooding.
2. Open the dispensing faucet at the sink. Close the tank shut-off valve. Make sure the angle stop valve for the incoming water is open. Open the small feed shut-off valve on feed valve assembly.
3. Observe all tubing and connections for several minutes to detect any leaks. In approximately 5 minutes, (assuming normal feed water pressure) the dispensing faucet should begin dripping.
4. Allow the faucet to run for up to 15 minutes, then close the faucet.
5. Check for leaks at all connections.
6. Open the tank shut-off valve.

Initial Flushing Procedure

1. Before the system can be used for drinking water production it must be adequately flushed. Each reservoir tank is dosed with a small amount of powdered sanitizer before shipment, typically a chlorinating agent, in order to ensure tank internal cleanliness. Also, the carbon filter cartridge will release a small amount of carbon fines during the first tankful of flow. This flushing procedure will allow any sanitizer or carbon fines to pass from the system.
2. Initial tank filling will take approximately one hour (based on average feed pressure). When the tank is full, the water pressure will have risen to the point where the automatic shut-off valve inside the system will stop the feed flow through the system. Actuation of the automatic shut-off valve can be determined by either checking for a lack of brine flow to the drain saddle, or by listening very closely near the dispensing faucet for absence of water flow sound through the air gap. When the tank has filled for the first time, it should be left undisturbed for at least 8 hours to ensure proper sanitization.
3. After 8 hours has elapsed, open the dispensing faucet fully and allow the product water to run out to drain at maximum flow. The initial discharge will be dark with the bulk of the carbon particle wash out. There may also be the scent of chlorinated water from the sanitizing agent. When the flow has diminished to a fast drip or small stream, close the dispensing faucet.
4. Fill and flush the tank at least three times prior to use. If necessary, repeat until the chlorination scent has disappeared. It is important that the flush be done at maximum flow (e.g. the tank must be full) to assist in rapid wash out. After this flushing procedure the system is ready for normal use.

WaterMaker^{FIVE} Installation Checklist

1. System is located where it will not be subject to physical impacts or rough contact by heavy objects.
2. Feed water pressure to the unit is no less than 40 psi and no greater than 80 PSI.
3. Ensure the plastic retainer clip that holds the desalinator cartridge in place is fully engaged and locked in place. The slide locks must snap into place in the slots. If the clip does not snap easily into place through the slots it means the cartridge is not fully inserted into the connectors. Press top or bottom of cartridge to engage connectors until it snaps into place properly.
4. All tubing connections, especially push-in quick connections, are fully inserted.
5. Tubing connected between the faucet and the drain saddle fitting (the fitting attached to the sink drain pipe) runs "down-hill" to the drain. There should be no loops or places where water would not flow out to the drain.
6. Angle stop valve is open. The small shut-off valve on the feed valve assembly is open.
7. Within one to two hours after initial application of water pressure, check again for leaks especially at the tank, faucet tubing and connectors. These parts will not see full pressure until approximately 2 hours after the system is activated.
8. Flush three tankfuls of product water to drain. If a chlorine scent persists, repeat flushing procedure.

WaterMaker^{FIVE} Maintenance

Cartridge Replacement

1. Close the small shut-off valve on the feed valve assembly.
2. Close the tank shut-off valve.
3. Open the dispensing faucet to relieve system pressure. Close dispensing faucet when flow has stopped.
4. Remove the cover from the front of the system. Remove the retaining clip. Pull the cartridge off the system evenly at top and bottom. Dispose of used cartridge.
6. Install the new cartridge, rocking gently from side to side as necessary until the cartridge tubes are properly engaged in the unit connectors. Install the retaining clip, ensuring the slide locks snap into place in the slots. If the clip does not snap easily into place through the slots it means the cartridge is not fully inserted into the connectors. Press the top or bottom of the cartridge to engage the connector so that it snaps fully into place. Failure to properly install the retaining clip will result in accidental leaks and flooding.
7. Open the small shut-off valve on the feed valve assembly. Open the dispensing faucet.
8. Close dispensing faucet after water starts running.
9. Observe system for any leaks, especially at newly replaced cartridge.
10. Open the tank shut-off valve.
11. The system should be flushed at least once as described in System Activation and Flushing.

Post Filter Replacement

1. Close the small shut-off valve on the feed valve assembly.
2. Close the tank shut-off valve.
3. Open the dispensing faucet.
4. Close the dispensing faucet when the water stops flowing.
5. Locate the inline filter on the faucet line.
6. Remove the tubing by depressing the collet towards the filter and pulling the blue tubing from the filter.
7. Remove the other side of the blue tubing as described above.
8. Reverse the above steps to install the new inline filter, making sure that the tubing is pressed in as far as possible.
9. Open the small shut-off valve on the feed valve assembly. Observe system for any leaks, especially at newly replaced cartridge.
10. Open the tank shut-off valve.
11. The system should be flushed at least once as described in System Activation and Flushing.

WaterMaker^{FIVE}

Please fill out the following information at the time of installation. Save for future reference.

Model: WaterMaker Five WM5-50

Date Code: _____

Install Date: _____

Sold by: _____

Installed By: _____

Service Center
Phone Number: _____